

Race Shuttle

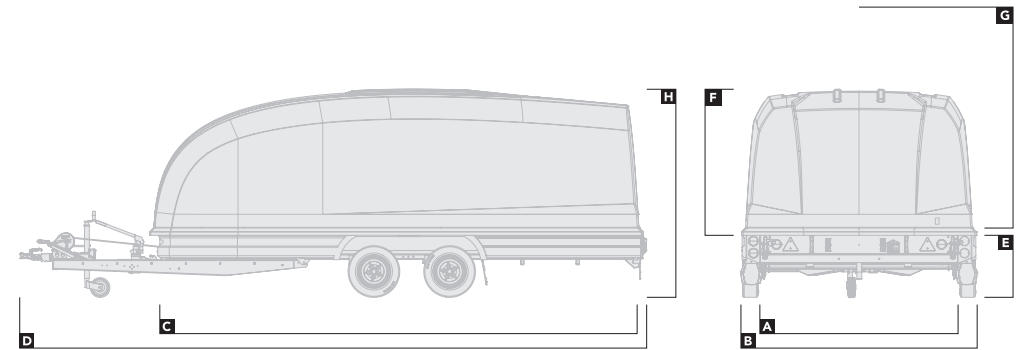

Overview

		330-	
		4319-26-2-12	4719-30-2-12
DIMENSIONS		dimensions in metres	
Bed width	A	1.95	1.95
Overall width	B	2.32	2.34
Bed length	C	4.3	4.7
Overall length	D	5.82	6.2
Bed height	E	0.42	0.42
Internal height	F	1.53	1.6
Door aperture height	G	2.4	2.5
Overall height	H	1.94	1.99
CAPACITY		weight in kg	
Gross capacity		2,600	3,000
Load capacity		1,765	2,070

Load capacity will vary depending on options fitted - For accurate information on weights and pricing, use our interactive configurator at www.brianjamestrailers.co.uk

Equipment

		330-	
		4319-26-2-12	4719-30-2-12
EXTERIOR		● Standard ○ Option	
Full LED lighting		●	●
LOADING			
Loading ramps - 2.5m		●	●
Manual / Electric winch		○	○
Manual tilt-bed		●	●
LOAD RESTRAINT			
Tie-down straps		●	●
Wheel chocks / Stop bar		○	○
RUNNING GEAR			
Alloy wheels - Anthracite		●	●
Locking hitch		●	●
Spare wheel		●	●
STORAGE			
Tyre rack		○	○

Loading angles

		330-	
		4319-26-2-12	4719-30-2-12
Loading ramps - 2.5m		2.5°	3.1°