

# Tipper

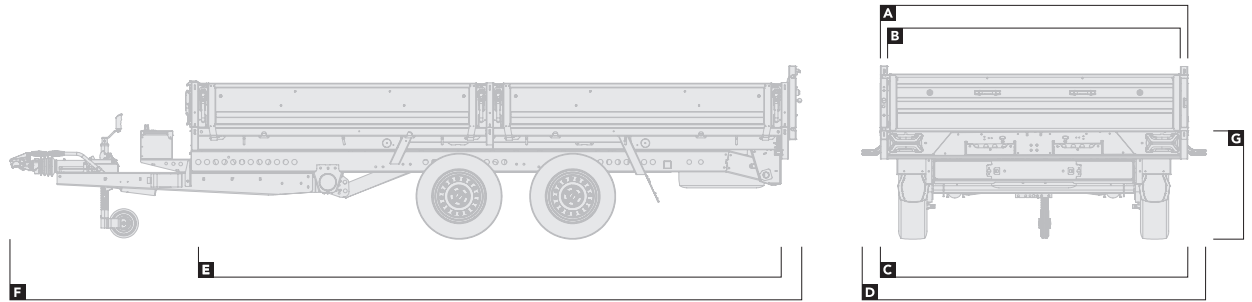

## Overview

		526-					
		3116-27-2-12	3116-35-2-12	3620-35-2-12	3620-35-3-12	4020-35-2-12	4020-35-3-12
<b>DIMENSIONS</b>		dimensions in metres					
Bed width (excl. sides)	<b>A</b>	1.69	1.69	2.09	2.09	2.09	2.09
Bed width (inc. sides)	<b>B</b>	1.6	1.6	2.0	2.0	2.0	2.0
Overall width (excl. marker lamp)	<b>C</b>	1.71	1.71	2.11	2.11	2.11	2.11
Overall width (inc. marker lamp)	<b>D</b>	–	–	2.34	2.34	2.34	2.34
Bed length	<b>E</b>	3.2	3.2	3.7	3.7	4.1	4.1
Overall length	<b>F</b>	4.53	4.53	5.03	5.03	5.43	5.43
Bed height	<b>G</b>	0.71	0.73	0.73	0.71	0.73	0.71
<b>CAPACITY</b>		weight in kg					
Gross capacity		2,700	3,500	3,500	3,500	3,500	3,500
Load capacity		1,830	2,495	2,361	2,328	2,370	2,300

## Loading angles

		526-					
		3116-27-2-12	3116-35-2-12	3620-35-2-12	3620-35-3-12	4020-35-2-12	4020-35-3-12
Loading ramps - 1.8m		24°	24°	24°	24°	24°	24°
Loading ramps - 2.35m		18°	18°	18°	18°	18°	18°

Load capacity will vary depending on options fitted - For accurate information on weights and pricing, use our interactive configurator at [www.brianjamestrailers.co.uk](http://www.brianjamestrailers.co.uk)

# Tipper

## Equipment

	526-	3116-35-2-12	3620-35-2-12	3620-35-3-12	4020-35-2-12	4020-35-3-12
<b>DECK</b>						
Reinforced deck	●	●	●	●	●	●
<b>EXTERIOR</b>						
Body trim available in Blue, Red, Anthracite, Black & Yellow	●	●	●	●	●	●
Full exterior LED lighting	●	●	●	●	●	●
<b>HYDRAULIC RAMS</b>						
Single ram	●	●	–	–	–	–
Twin rams	–	–	●	●	●	●
<b>LOADING</b>						
Electric winch	○	○	○	○	○	○
Loading ramps - 1.8m or 2.35m	○	○	○	○	○	○
Support stands	○	○	○	○	○	○
<b>LOAD RESTRAINT</b>						
Tie-down straps	○	○	○	○	○	○
<b>RUNNING GEAR</b>						
Alloy wheels - Anthracite	○	○	○	○	○	○
Battery w/ trickle charger	●	●	●	●	●	●
Mains battery charger	○	○	○	○	○	○
Locking hitch	●	●	●	●	●	●
Spare wheel	●	●	●	●	●	●
<b>SIDES</b>						
2-way tailgate - available in 5 colours	●	●	●	●	●	●
Side-hinged doors	○	○	○	○	○	○
Dropsides - available in 5 colours	●	●	●	●	●	●
Double-height side extensions - available in 5 colours	○	○	○	○	○	○
Side extensions	○	○	○	○	○	○
Heavy-duty side extensions	○	○	○	○	○	○
Ladder rack	○	○	○	○	○	○
<b>STORAGE</b>						
Storage box	●	●	●	●	●	●

# Tipper

## Equipment

	526-					
	3116-27-2-12	3116-35-2-12	3620-35-2-12	3620-35-3-12	4020-35-2-12	4020-35-3-12
<b>DECK</b>						
	● Standard ○ Option – Not available					
Reinforced deck	●	●	●	●	●	●
<b>EXTERIOR</b>						
Body trim available in Blue, Red, Anthracite, Black & Yellow	●	●	●	●	●	●
Full exterior LED lighting	●	●	●	●	●	●
<b>HYDRAULIC RAMS</b>						
Single ram	●	●	–	–	–	–
Twin rams	–	–	●	●	●	●
<b>LOADING</b>						
Electric winch	○	○	○	○	○	○
Loading ramps - 1.8m or 2.35m	○	○	○	○	○	○
Support stands	○	○	○	○	○	○
<b>LOAD RESTRAINT</b>						
Tie-down straps	○	○	○	○	○	○
<b>RUNNING GEAR</b>						
Alloy wheels - Anthracite	○	○	○	○	○	○
Battery w/ trickle charger	●	●	●	●	●	●
Mains battery charger	○	○	○	○	○	○
Locking hitch	●	●	●	●	●	●
Spare wheel	●	●	●	●	●	●
<b>SIDES</b>						
2-way tailgate - available in 5 colours	●	●	●	●	●	●
Side-hinged doors	○	○	○	○	○	○
Dropsides - available in 5 colours	●	●	●	●	●	●
Double-height side extensions - available in 5 colours	○	○	○	○	○	○
Side extensions	○	○	○	○	○	○
Heavy-duty side extensions	○	○	○	○	○	○
Ladder rack	○	○	○	○	○	○
<b>STORAGE</b>						
Storage box	●	●	●	●	●	●